

# SRH 102 mm DEFLECTION ISOLATION HANGERS

S-I UNITS (mm AND kg)

TYPE	L	H	W	A	B	Dmax
4-100/1600	81	406	238	102	152	22

STANDARD RATINGS				SPRING COIL			INSERT COLOR
TYPE	SIZE	LOAD	DEFL.	COLOR	FREE HT.	O.D.	
SRH	4-100	45	104	GRAY	254	143	WHITE
SRH	4-250	113	107	BLUE	254	143	WHITE
SRH	4-500	227	105	GREEN	254	143	YELLOW
SRH	4-750	340	107	BLACK	254	143	YELLOW
SRH	4-1000	454	109	RED	254	143	YELLOW
SRH	4-1250	567	111	BROWN	254	143	YELLOW
SRH	4-1600	726	111	ORANGE	254	143	PINK

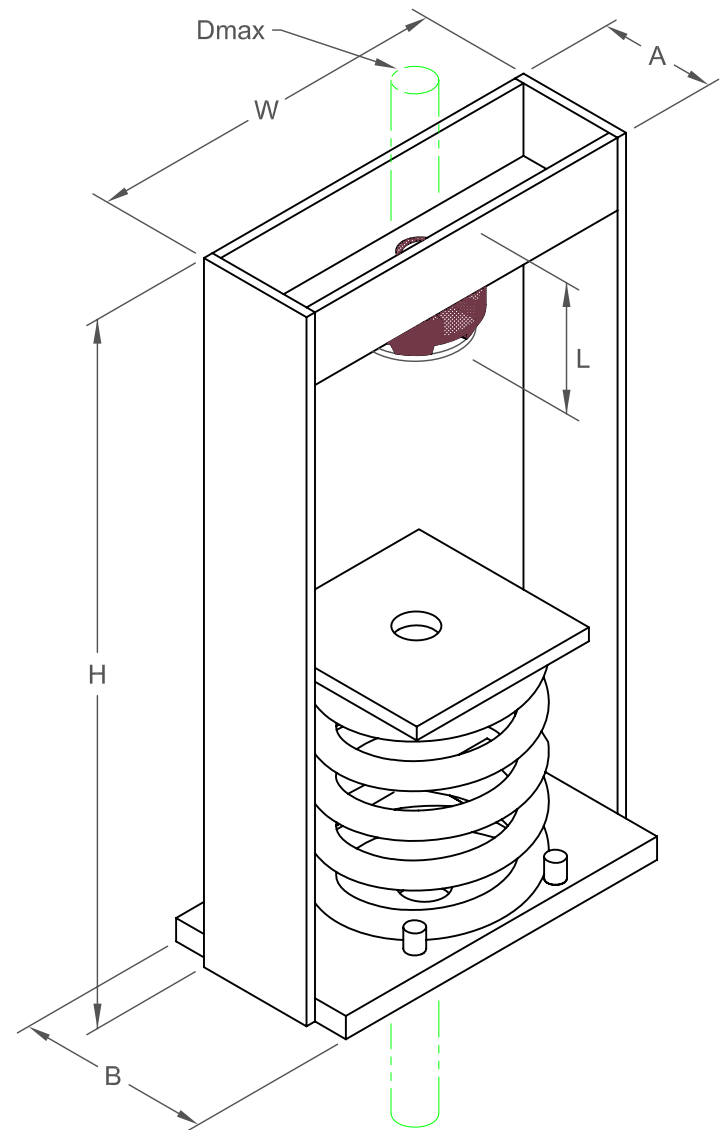

## SPECIFICATIONS:

- SPRING ELEMENTS AND BRACKETS ARE POWDER COATED
- LOAD PLATES ARE BRIGHT ZINC PLATED
- ISOLATION HANGERS HAVE A MINIMUM  $K_x/K_y$  RATIO OF 1.2
- SPRING ELEMENTS ARE SAFE AT SOLID LOADING
- HANGER BRACKETS WILL CARRY (5) TIMES OVERLOAD WITHOUT FAILURE
- HANGER BRACKETS WILL ALLOW 30° ROD MISALIGNMENT WITHOUT SHORT CIRCUITING



KINETICS NOISE CONTROL, INC  
 6300 IRELAN PL,  
 DUBLIN, OH 43017 USA  
 Ph: 614 889-0480, Fax: 614 889-0540  
 www.kineticsnoise.com

Model:  
**SRH**  
**4-100/1600**

By: **JMJ**  
 Date: **11/3/03**  
 Revised: **/**

Drawing No:  
**S-03.37-41(M)**