

SRH 51 mm DEFLECTION ISOLATION HANGERS

S-I UNITS (mm AND kg)

TYPE	L	H	W	A	Dmax
2-2000/2500	44	305	152	152	25
2-2750/3250	44	305	152	152	25

STANDARD RATINGS				SPRING COIL				INSERT COLOR
TYPE	SIZE	LOAD	DEFL.	COLOR		FREE	O.D.	
				OUTER	INNER	HT.		
SRH	2-2000	907	53	ORANGE		178	127	BLACK
SRH	2-2500	1134	53	BLUE		178	127	BLACK
SRH	2-2750	1247	54	BLUE	BLUE	178	127	BLACK
SRH	2-3025	1372	54	BLUE	GREEN	178	127	BLACK
SRH	2-3250	1474	54	BLUE	BLACK	178	127	BLACK

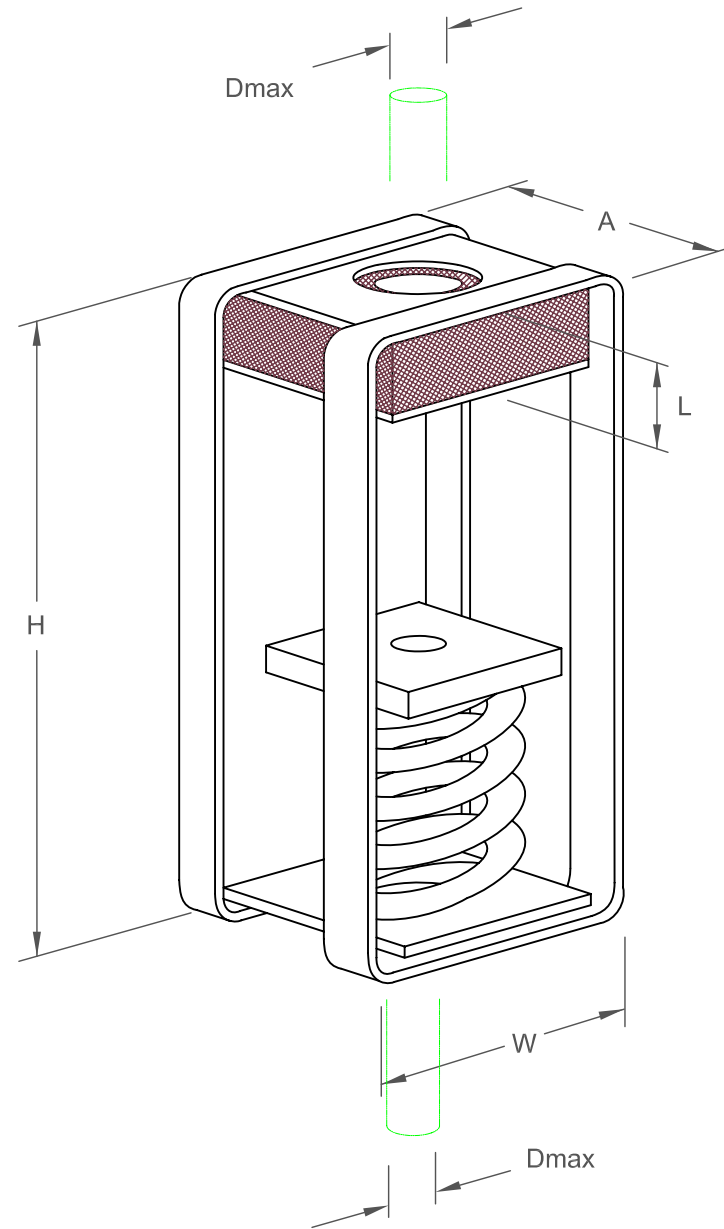

SPECIFICATIONS:

- SPRING ELEMENTS ARE POWDER COATED, BRACKETS ARE PAINTED
- LOAD PLATES ARE BRIGHT ZINC PLATED
- ISOLATION HANGERS HAVE A MINIMUM K_x/K_y RATIO OF 1.4
- SPRING ELEMENTS ARE SAFE AT SOLID LOADING
- HANGER BRACKETS WILL CARRY (5) TIMES OVERLOAD WITHOUT FAILURE
- HANGER BRACKETS WILL ALLOW 30° ROD MISALIGNMENT WITHOUT SHORT CIRCUITING



KINETICS NOISE CONTROL, INC
 6300 IRELAN PL,
 DUBLIN, OH 43017 USA
 Ph: 614 889-0480, Fax: 614 889-0540
 www.kineticsnoise.com

Model:
 SRH
 2-2000/2500

By: JMJ
 Date: 10/28/03
 Revised: /

Drawing No:
 S-03.37-24(M)