

SRH 1" DEFLECTION ISOLATION HANGERS

IP UNITS (INCHES AND POUNDS)

TYPE	L	H	W	A	Dmax
1-1250/1700	2.00	8.59	5.58	3.63	0.88

STANDARD RATINGS				SPRING COIL			INSERT
TYPE	SIZE	LOAD	DEFL.	COLOR	FREE HT.	O.D.	COLOR
SRH	1-1250	1250	1.38	BROWN	4.20	3.00	PINK
SRH	1-1700	1700	1.35	ORANGE	4.20	3.00	PINK

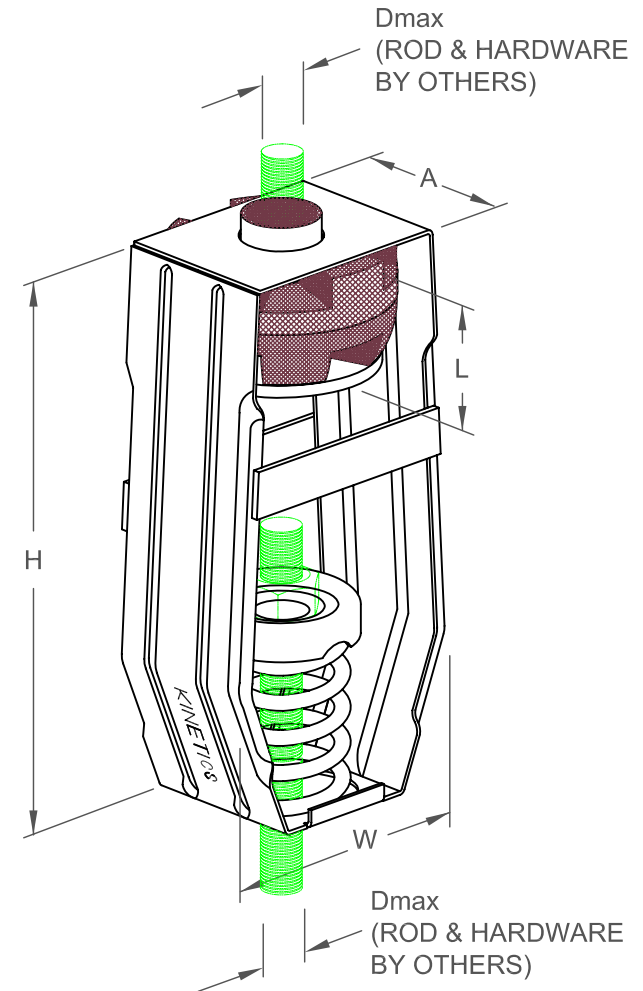

SPECIFICATIONS:

- SPRING ELEMENTS AND BRACKETS ARE POWDER COATED
- LOAD PLATES ARE BRIGHT ZINC PLATED
- ISOLATION HANGERS HAVE A MINIMUM Kx/Ky RATIO OF 1.2
- SPRING ELEMENTS ARE SAFE AT SOLID LOADING
- HANGER BRACKETS WILL CARRY (5) TIMES OVERLOAD WITHOUT FAILURE
- ISOLATION HANGERS HAVE A TYPICAL OVERLOAD OF 50%
- HANGER BRACKETS WILL ALLOW 30° ROD MISALIGNMENT WITHOUT SHORT CIRCUITING
- "NO SHORT" STEP CAP



KINETICS NOISE CONTROL, INC
 6300 IRELAN PL,
 DUBLIN, OH 43017 USA
 Ph: 614 889-0480, Fax: 614 889-0540
 www.kineticsnoise.com

Model:
SRH
 1-1250/1700

By: **JMJ**
 Date: **02/26/03**
 Revised: **/**

Drawing No:
S-03.37-13