

NOTE:
ALL DIMENSIONS SHOWN IN
INCHES AND MILLIMETERS.

MODEL	SPRING COLOR	RATED LOAD LB/KG	RATED DEFLECTION IN/MM	DIMENSIONS IN INCHES				
				A IN/MM	B IN/MM	C IN/MM	D IN/MM	E IN/MM
SH-2-260	BLUE	260/118	2.14/54	5.58/142	8.59/218	3.63/92	.88/22	4.00/100
SH-2-465	GREEN	465/211	2.00/50	5.58/142	8.59/218	3.63/92	.88/22	4.00/100
SH-2-720	BLACK	720/328	2.00/50	5.58/142	8.59/218	3.63/92	.88/22	4.00/100
SH-2-850	WHITE	850/386	2.03/52	5.58/142	8.59/218	3.63/92	.88/22	4.25/108
SH-2-1025	BEIGE	1025/466	2.00/50	5.58/142	8.59/218	3.63/92	.88/22	4.25/108
SH-2-1200	CHROME	1200/546	2.03/52	5.58/142	8.59/218	3.63/92	.88/22	4.50/114

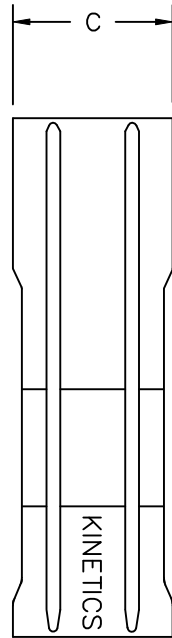

- SH-2 ISOLATION HANGERS HAVE A MINIMUM K_x/K_y OF 1.4
- SH-2 SPRING ELEMENTS ARE SAFE FOR SOLID LOADING
- SH-2 HANGER BRACKETS WILL CARRY (5) TIMES OVERLOAD WITHOUT FAILURE
- SH-2 HANGER BRACKETS WILL ALLOW 30° ROD MISALIGNMENT WITHOUT SHORT CIRCUITING
- SH-2 SPRING ELEMENTS AND BRACKETS ARE POWDER COATED. LOAD PLATES ARE BRIGHT ZINC PLATED.
- SH-2 HANGERS CONTAIN AN UPPER NEOPRENE ELEMENT

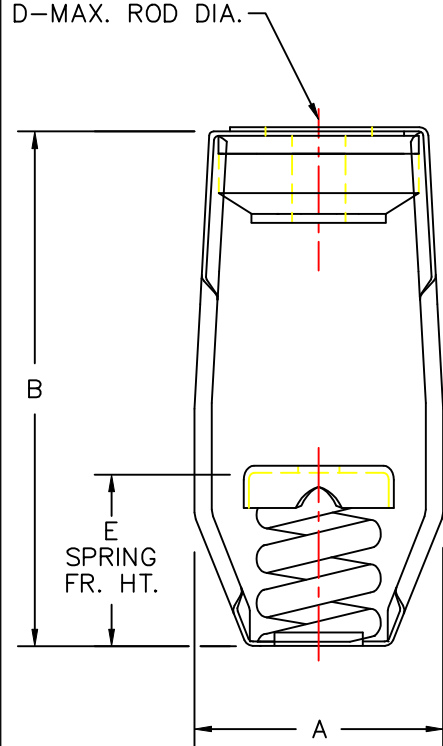

TITLE
MODEL SH-2 HANGER

LAST DATE
REVISED
3/20/96

DRAWN BY
DW

DRAWING NO. S-DWG
S-03.36-2B