

SFH 1" DEFLECTION ISOLATION HANGER

TYPE	L	H	W	A	Dmax
1-35/370	1.13	7.38	3.69	2.25	0.50
1-500/805	1.25	7.38	3.69	2.25	0.63

I-P UNITS (INCHES AND POUNDS)

STANDARD RATINGS

TYPE	SIZE	COIL	COIL FREE HT	O.D.	RATED LOAD
SFH	1-35	BLUE	3.19	1.75	35
SFH	1-70	GREEN	3.19	1.75	70
SFH	1-125	GRAY	3.19	1.75	125
SFH	1-245	BROWN	3.19	1.75	245
SFH	1-370	ORANGE	3.19	1.75	370
SFH	1-500	BEIGE	3.19	1.75	500
SFH	1-600	CHROME	3.19	1.75	600
* SFH	1-700	BGE/WHT	3.19	1.75	700
* SFH	1-805	CHR/WHT	3.19	1.75	805

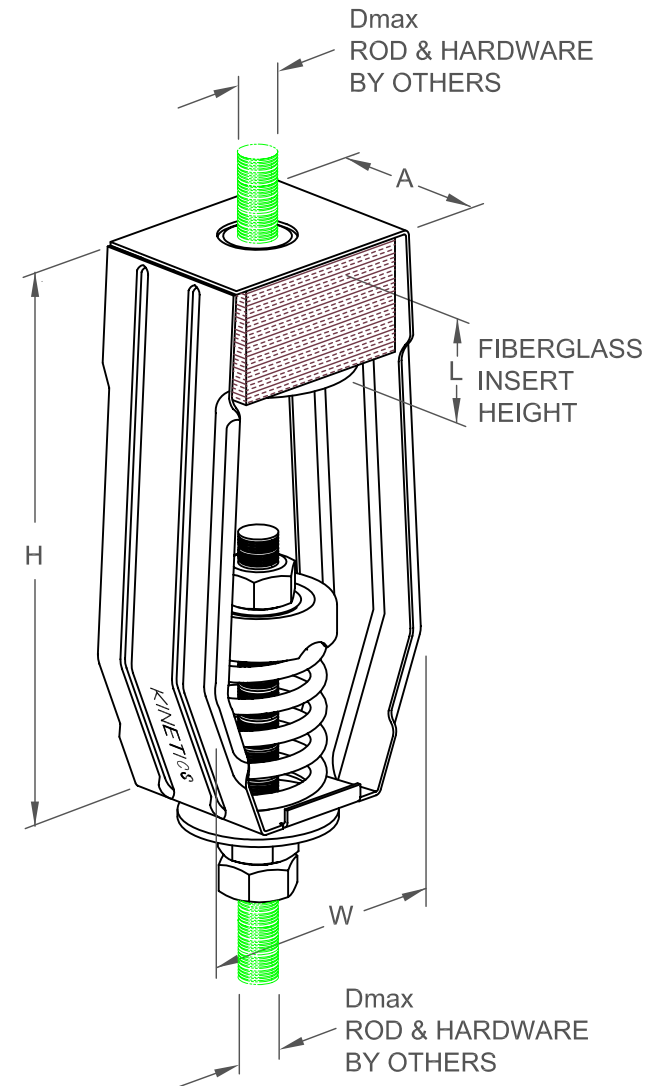

SPECIFICATIONS:

- SPRING ELEMENTS AND BRACKETS ARE POWDER COATED
- LOAD PLATES ARE BRIGHT ZINC PLATED
- ISOLATION HANGERS HAVE A TYPICAL OVERLOAD OF 50%
- ISOLATION HANGERS HAVE A MINIMUM K_x/K_y RATIO OF 1.0
- SPRING ELEMENTS ARE SAFE AT SOLID LOADING
- HANGER BRACKETS WILL CARRY (5) TIMES OVERLOAD WITHOUT FAILURE
- HANGER BRACKETS WILL ALLOW 30° ROD MISALIGNMENT WITHOUT SHORT CIRCUITING EXCEPT AS NOTED *
- ISOLATION HANGERS MARKED * HAVE A NEOPRENE BOTTOM SPRING CAP WITH GROMMET
- "NO SHORT" STEP CAP



KINETICS NOISE CONTROL, INC
6300 IRELAN PL,
DUBLIN, OH 43017 USA
Ph: 614 889-0480, Fax: 614 889-0540
www.kineticsnoise.com

Model:
SFH
1-35/805

By: JMJ
Date: 03/10/03
Revised: 08/23/04 / BB

Drawing No:
S-03.35-11