

KINETICS™

Structural Beam Base Model SBB

Description

Model SBB steel beam bases meet all specifications for equipment bases, and provide rigid, distortion free mounting and anchor beams for vibration isolated mechanical equipment.

Model SBB bases incorporate a structural steel beam sections, with welded-on isolator support brackets, and pre-located and drilled anchor bolt holes for bolting to equipment to be supported.

Standard Model SBB beam bases are structural steel members with minimum section depths equal to 8% of the longest span between supporting isolators, or a minimum of 6" (152 mm), whichever is greater, to assure adequate stiffness of the beam. All Model SBB bases are sized specifically for the equipment to be supported, and have equipment anchor bolt holes pre-located and drilled as required for attachment to supported equipment. Isolator brackets are sized as required for isolators to be used and loads to be supported, and are selected to assure the lowest possible mounting height of supported equipment.

Features

- Structural steel beam base
- Standard section depths 3" through 12" (76 mm through 305 mm)
- Beam members include WF beams, Angles, and I-beams
- Beam lengths as required
- Height saving welded-on steel isolator brackets
- Pre-located and drilled anchor bolt holes

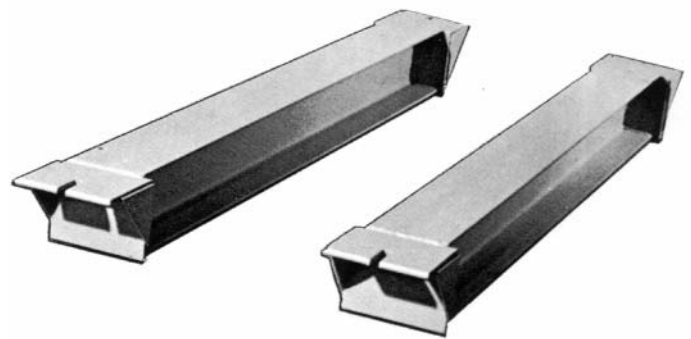

Application

Kinetics Model SBB steel beam bases are specifically designed and engineered to support mechanical equipment requiring a supplemental mounting beam system, but having integral frame stiffness between driving and driven members, when the supplemental beam base is to be supported by Kinetics vibration isolators as part of the noise and vibration isolation of the equipment.

Steel beam bases used to support mechanical equipment provide a means of attaching supporting isolators while maintaining a rigid supporting surface for the isolated equipment, and can provide a means by which equipment can be stabilized and motion reduced by lowering the equipment center of gravity.

Typical use of Kinetics Model SBB steel beam bases, supported by Kinetics noise and vibration isolators, includes support and isolation of absorption chillers, hermetic centrifugal chillers, package boilers, cooling towers, and similar types of equipment.

Specifications

Bases shall be structural beam sections, with welded-on isolator support brackets and pre-located and drilled anchor bolt holes, and shall be designed and supplied by the isolation materials manufacturer.

Beam sections shall not be structurally connected to each other. Minimum section depth of each member shall be equal to 8% of the longest span between supporting isolators, or as shown on the drawings or indicated on the project documents.

Isolator support brackets shall be welded to the structural beams as required to obtain the lowest mounting height for the supported equipment.

Structural Bases Bases shall be model SBB, as manufactured by Kinetics Noise Control, Inc.

Standard Structural Members, In. (mm) E	Width of Flange In. (mm)	Weight Lbs./ft. kg	Dimensions, In. (mm)		
			A	B	C
3" x 2" (76 mm x 51 mm) Angle	2.0 (51)	4.1 (5.8)	As Required		3 (76)
4" x 3" (102 mm x 76 mm) Angle	3.0 (76)	5.8 (8.2)			5 (127)
4" (102 mm) I-Beam	2.6 (66)	7.7 (10.9)	As Required		5 (127)
4" (102 mm) WF Beam	4.0 (102)	13.0 (18.4)			5 (127)
6" x 3½" (152 mm x 89 mm) Angle	3.5 (89)	9.8 (13.9)	As Required		7 (178)
6" (152 mm) WF Beam	4.0 (102)	8.5 (12.0)			7 (178)
8" (203 mm) WF Beam	4.0 (102)	10.0 (14.1)			9 (229)
10" (254 mm) WF Beam	4.0 (102)	11.5 (16.3)	As Required		11 (279)
12" (305 mm) WF Beam	4.0 (102)	14.0 (19.8)			13 (330)

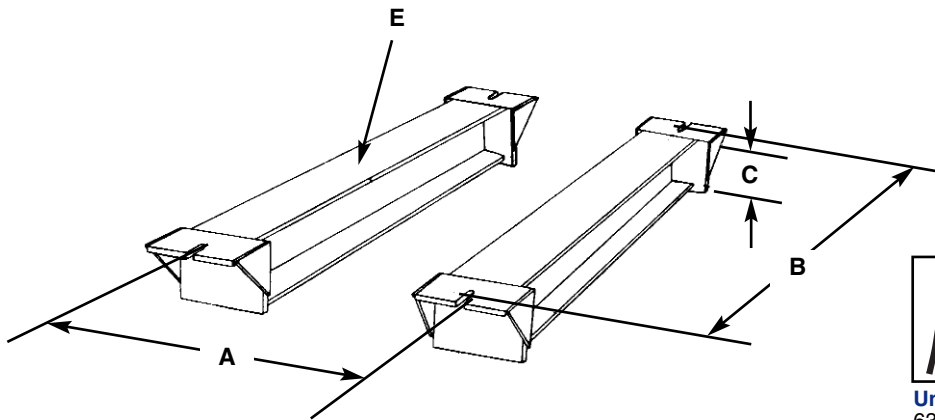

United States 6300 Irelan Place P.O. Box 655 Dublin, Ohio 43017 Phone: 614-889-0480 Fax: 614-889-0540	Canada 1720 Meyerside Drive Mississauga, Ontario L5T 1A3 Phone: 905-670-4922 Fax: 905-670-1698
-----------------------------------------------------------------------------------------------------------------------------	----------------------------------------------------------------------------------------------------------------------

www.kineticsnoise.com
sales@kineticsnoise.com

Kinetics Noise Control, Inc. is continually upgrading the quality of our products. We reserve the right to make changes to this and all products without notice.