

NEGATIVE PRESSURE RATING FOR ALL SIZES: 26" (660) HG  
 TEMPERATURE FOR RATED PRESSURE: 170 DEG F (77 DEG C)  
 MAX ALLOWABLE TEMPERATURE: 225 DEG F (107 DEG C)  
 STANDARD FLANGES PER ANSI 125/150# 250/300#, BS, DIN, JIS, FLANGES ALSO AVAILABLE BUT NOT SHOWN.

MATERIALS  
 FLANGES: MILD STEEL  
 WIRE CORD (COLLAR): HARDENED STEEL WIRE  
 BODY: NEOPRENE (STD)  
 BODY CORD: NYLON TIRE CORD  
 OPTIONAL BODY MATERIALS AVAILABLE

APPLICABLE FLUIDS FOR STD BODY: WATER, WARM WATER, SEAWATER, WEAK ACIDS, ALKALIES, COMPRESSED AIR, ETC.

NOM SIZE	LENGTH-L	APPROX A (STD HDWR)	STD HARDWARE (BY OTHERS)	AXIAL COMPRESSION	AXIAL ELONGATION	TRANSVERSE MOVEMENT	ANGULAR DEFLECTION	MAX PRESSURE	WEIGHT CONNECTOR	WEIGHT CONTROL RODS
1.5 (38)	7 (178)	.68 (17)	4 -1/2 -11	2.00 (51)	1.188 (30)	1.75 (44)	45 DEG	225 (15.5)	6.8 (3.1)	4.8 (2.2)
2 (50)	7 (178)	.75 (19)	4 -5/8 -11	2.00 (51)	1.188 (30)	1.75 (44)	45 DEG	225 (15.5)	9.0 (4.1)	7.0 (3.2)
2.5 (63)	7 (178)	.88 (22)	4 -5/8 -11	2.00 (51)	1.188 (30)	1.75 (44)	43 DEG	225 (15.5)	13.3 (6.1)	8.0 (3.6)
3 (75)	7 (178)	.94 (24)	4 -5/8 -11	2.00 (51)	1.188 (30)	1.75 (44)	38 DEG	225 (15.5)	14.3 (6.5)	8.6 (3.64)
4 (100)	9 (229)	.94 (24)	8 -5/8 -11	2.00 (51)	1.375 (35)	1.562 (40)	34 DEG	225 (15.5)	20.3 (9.2)	8.0 (3.6)
5 (127)	9 (229)	.94 (24)	8 -3/4 -10	2.00 (51)	1.375 (35)	1.562 (40)	29 DEG	225 (15.5)	24.5 (11.1)	8.3 (3.8)
6 (152)	9 (229)	1 (25)	8 -3/4 -10	2.00 (51)	1.375 (35)	1.562 (40)	25 DEG	225 (15.5)	29.5 (13.4)	11.7 (5.3)
8 (203)	13 (330)	1.13 (29)	8 -3/4 -10	2.375 (60)	1.375 (35)	1.375 (35)	19 DEG	225 (15.5)	43.8 (19.9)	15.4 (7.0)
10 (254)	13 (330)	1.19 (48)	12 -7/8 -9	2.375 (60)	1.375 (35)	1.375 (35)	15 DEG	225 (15.5)	65.5 (29.7)	24.5 (11.4)
12 (305)	13 (330)	1.25 (32)	12 -7/8 -9	2.375 (60)	1.375 (35)	1.375 (35)	13 DEG	225 (15.5)	95 (43.2)	31 (14.1)
14 (356)	13.75 (349)	1.38 (35)	12 -1 -8	1.75 (44)	1.188 (30)	1.188 (30)	09 DEG	150 (10.2)	112 (50.7)	32 (14.5)
16 (406)	13.75 (349)	1.44 (37)	12 -1 -8	1.75 (44)	1.188 (30)	1.188 (30)	08 DEG	125 (8.6)	132 (59.8)	30.8 (14)
18 (457)	13.75 (349)	1.56 (40)	16 -1 1/8 -7	1.75 (44)	1.188 (30)	1.188 (30)	07 DEG	125 (8.6)	146 (66.1)	36.1 (16.4)
20 (508)	13.75 (349)	1.69 (43)	20 -1 1/8 -7	1.75 (44)	1.188 (30)	1.188 (30)	07 DEG	125 (8.6)	182 (82.4)	35.5 (16.1)
24 (610)	13.75 (349)	1.88 (48)	20 -1 1/8 -7	1.75 (44)	1.188 (30)	1.188 (30)	05 DEG	110 (9.6)	220 (99.7)	48 (21.7)

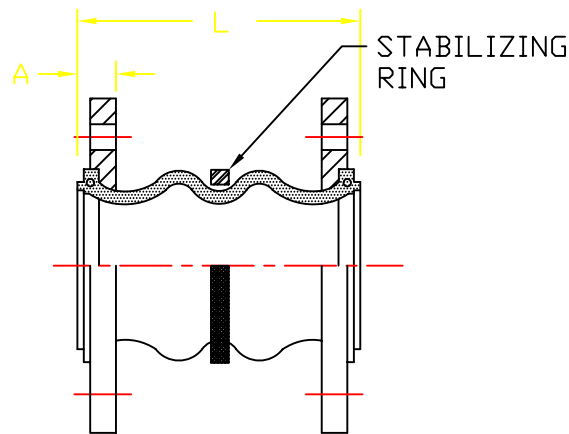

KINFLEX FTC

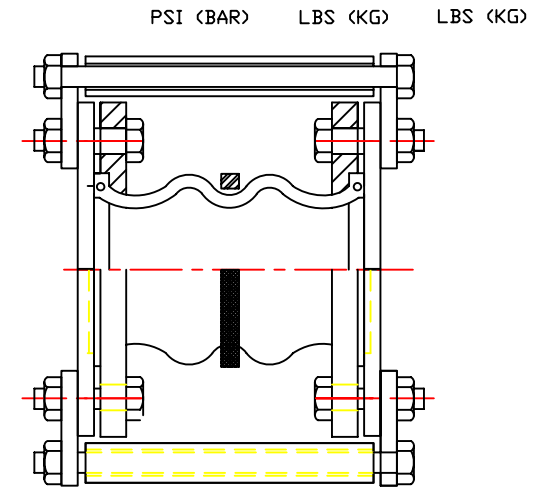

KINFLEX FTC WITH CONTROL RODS

ALL DIMS IN INCHES (MM) EXCEPT AS NOTED

TAG	QTY	PIPE SIZE	CONTROL RODS
			YES <input type="checkbox"/> NO <input type="checkbox"/>
			YES <input type="checkbox"/> NO <input type="checkbox"/>
			YES <input type="checkbox"/> NO <input type="checkbox"/>
			YES <input type="checkbox"/> NO <input type="checkbox"/>
			YES <input type="checkbox"/> NO <input type="checkbox"/>

Drawn By: DC Date: 10/29/96 Approved By: PWM

Checked By: Scale: None



Drawing No.: S-05.05-01D

WARNING: Control Units Must Be Used To Protect This Part From Excessive Movement If Piping Is Not Properly Anchored. Expansion Joints May Operate In Pipelines Or Equipment Carrying Fluids And/Or Gases At Elevated Temperatures And Pressures. Normal Precautions Should Be Taken To Make Sure These Parts Are Installed Correctly And Inspected Regularly. Precautions Should Be Taken To Protect Personnel In The Event Of Leakage Or Splash.

Proposal/Inquiry/Order Number:

Customer Name:

Project Name:

Architect/Engineer:

Contractor:

DATE:

The above expansion joints and related hardware meet or exceed the physical, mechanical, or material specifications of the Rubber Expansion Joint Division Fluid Sealing Association. For additional information see the Association "Technical Handbook, Fifth Edition" Chapter 11, Paragraph a.1 and Tables II,III,IV.

REMARKS: