

FLS 2" DEFLECTION ISOLATOR IP UNITS (INCHES AND POUNDS)

A2, B2, L2, T2, D2 DIMENSIONS REFER TO OPTIONAL BASE-PLATE USED TO INCREASE RATING WHEN ATTACHED TO CONCRETE

TYPE	L	W	T	A	B	D	E	F	d	H
2-2000/4500	10.75	5.00	0.25	0.75	1.38	0.69	2.75	2.75	0.56	10.00

STANDARD RATINGS		SPRING COIL						
TYPE	SIZE	OUTER	INNER1	INNER2	FREE HT.	O.D.	RATED	
							LOAD	DEFL.
FLS	2-2000	ORANGE			7.00	5.00	2000	2.00
FLS	2-2500	BLUE			7.00	5.00	2500	2.00
FLS	2-2750	BLUE	BLUE		7.00	5.00	2750	2.00
FLS	2-3025	BLUE	GREEN		7.00	5.00	3025	2.02
FLS	2-3250	BLUE	BLACK		7.00	5.00	3250	2.00
FLS	2-3500	BLUE	ORANGE		7.00	5.00	3500	2.00
FLS	2-3900	BLUE	ORANGE	GREEN	7.00	5.00	3900	2.00
FLS	2-4100	BLUE	RED		7.00	5.00	4100	2.00
FLS	2-4500	BLUE	RED	GREEN	7.00	5.00	4500	2.00

2-2000/4500 REQUIRES 0.62 DIA x 4.00 MIN EMBED ANCHORS IN CONCRETE
(ALLOWABLE LOADS BASED ON 3000 PSI MIN CONCRETE)
2-2000/4500 ANCHOR BOLT TORQUE - 75 FT-LB, PULL TEST - 2670 LB

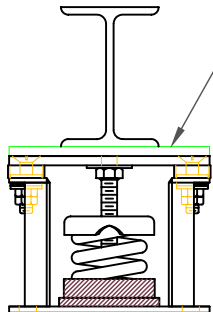
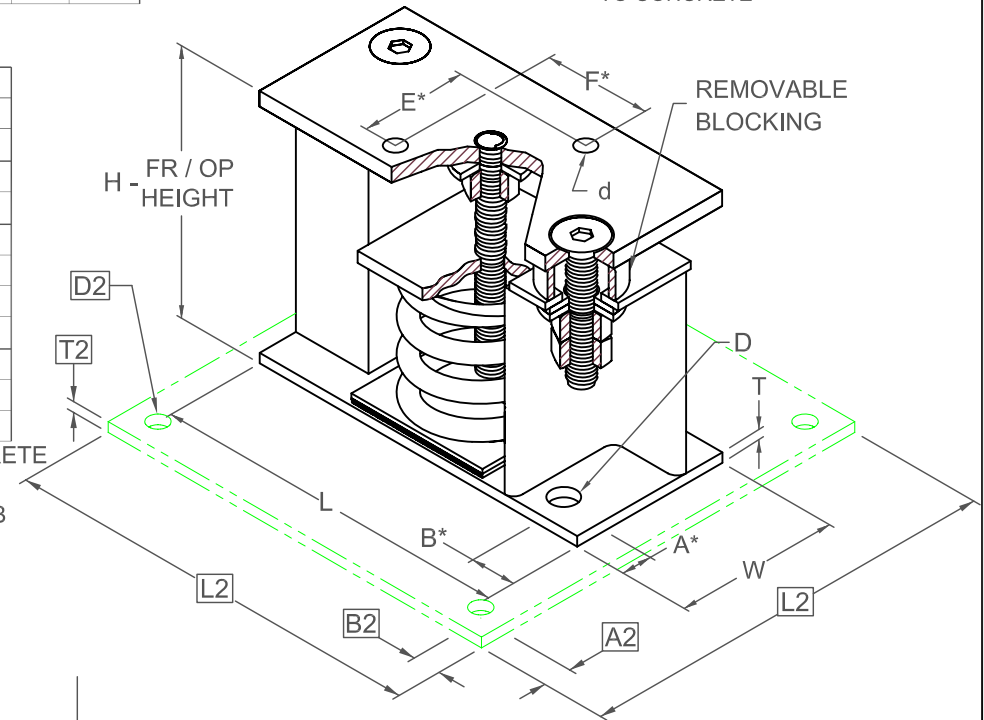

IF EQUIP SUPPORT STEEL IS 90° TO THE LONG ISOLATOR AXIS, AN ADD'L PLATE EQUAL IN THICKNESS TO THE TOP PLATE IS REQUIRED

SPECIFICATIONS:

- VERTICALLY AND LATERALLY RESTRAINED SPRING ISOLATOR WITH CONSTANT FREE AND OPERATING HEIGHT AND REPLACEABLE NEOPRENE SNUBBING ELEMENTS.
- MINIMUM COIL OVERLOAD OF 50%.
- MINIMUM Kx/Ky RATIO OF 1.0.
- ALL ELEMENTS SAFE AT SOLID LOADING.
- POWDER COATED COILS AND HOT DIPPED GALVANIZED BRACKET.
- HOUSINGS MAY BE USED FOR BLOCKING DURING EQUIPMENT ERECTION.

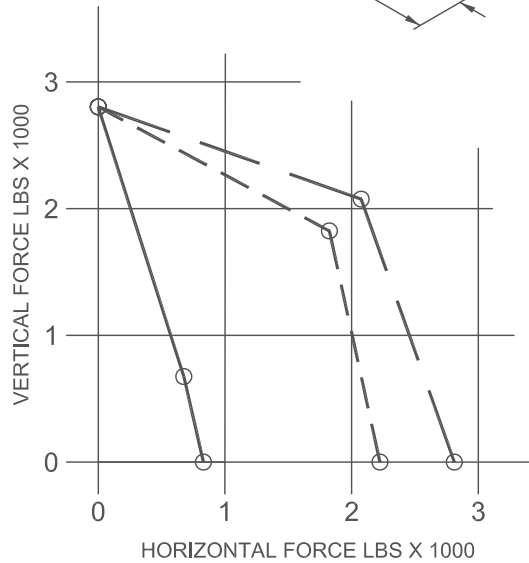

*ALL MOUNTING BOLT PATTERNS SYMMETRICAL ABOUT ISOLATOR CENTER-LINE

WELDED TO STEEL ---
THROUGH BOLTED - - -
ANCHORED TO CONCRETE ———

Computed horiz and vert seismic load combinations must fall within the restraint capacity envelope. Contact KNC for bolted to steel data.



KINETICS NOISE CONTROL, INC
6300 IRELAN PL,
DUBLIN, OH 43017 USA
Ph: 614 889-0480, Fax: 614 889-0540
www.kineticsnoise.com

Model:
**FLS-2-
2000 / 4500**

By: **JMJ**
Date: **07/09/02**
Revised: **5/5/06 / PWM**

Drawing No:
S-01.22-22