

**FDS 2" DEFLECTION ISOLATOR
IP UNITS (INCHES AND POUNDS)**

TYPE	L	W	T	A	E	D	H	TT	Z
2-8000B/10000B	12.00	11.00	0.60	0.75	5.50	0.81	11.75	0.75	1.25
2-11000B/18000B	12.00	11.00	0.60	0.75	5.50	0.81	11.75	1.00	1.50

STANDARD RATINGS		SPRING COIL						
TYPE	SIZE	COLOR			FREE HT.	O.D.	RATED	
		OUTER	INNER1	INNER2			LOAD	DEFL.
FDS	2-8000B	GRAY			7.00	5.00	8000	2.00
FDS	2-10000B	GRAY			7.00	5.00	10000	2.00
FDS	2-11000B	GRAY	GRAY		7.00	5.00	11000	2.00
FDS	2-12100B	GRAY	GRAY		7.00	5.00	12100	2.02
FDS	2-13000B	GRAY	GRAY		7.00	5.00	13000	2.00
FDS	2-14000B	GRAY	GRAY		7.00	5.00	14000	2.00
FDS	2-15600B	GRAY	GRAY	GRAY	7.00	5.00	15600	2.00
FDS	2-16400B	GRAY	GRAY		7.00	5.00	16400	2.00
FDS	2-18000B	GRAY	GRAY	GRAY	7.00	5.00	18000	2.00

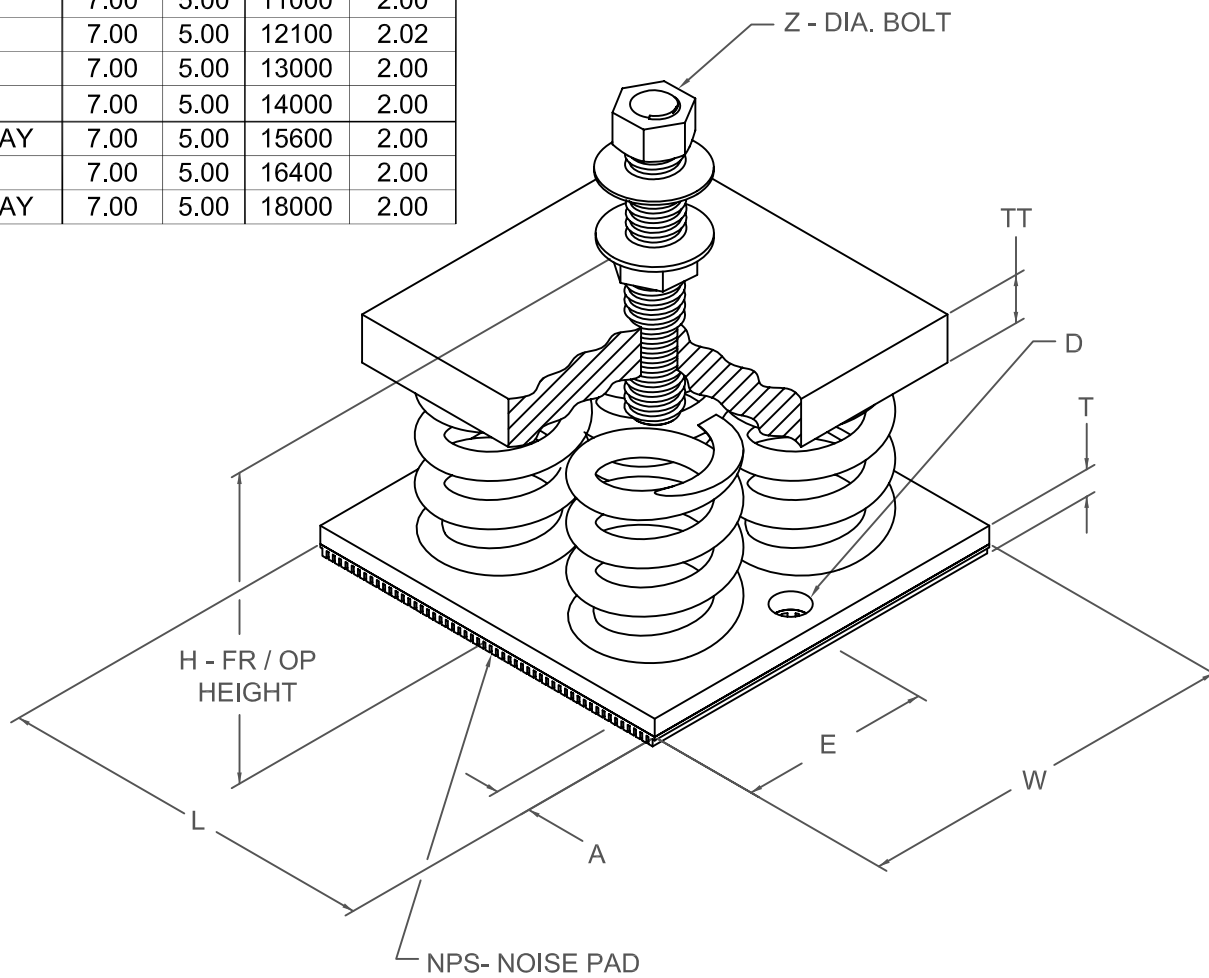

SPECIFICATIONS:

- LOAD PLATES ARE AFFIXED TO COIL SPRINGS
- FREE STANDING COIL SPRING ISOLATOR
- PAINTED SPRING ELEMENTS
- OTHER METALLIC COMPONENTS BRIGHT ZINC PLATED
- MINIMUM OVERLOAD OF 50%
- MINIMUM Kx/Ky RATIO OF 1.0
- ALL ELEMENTS SAFE AT SOLID LOADING
- ALL THREADED MEMBERS ARE AMERICAN STANDARD



KINETICS NOISE CONTROL, INC
6300 IRELAN PL,
DUBLIN, OH 43017 USA
Ph: 614 889-0480, Fax: 614 889-0540
www.kineticsnoise.com

Model:
**FDS-2-
8000B/18000B**

By: **JMJ**
Date: **04/10/02**
Revised: **01/09/04 / JMJ**

Drawing No:
S-01.20-25